

H4EKO-D

USER INSTRUCTIONS





CONTENT

1. INTRODUCTION	3
2. BOILER CHARACTERISTICS	3
3. TECHNICAL DESCRIPTION	3
4. TECHNICAL PARAMETERS.....	4
5. LIST OF REPLACEABLE SPARE PARTS.....	7
7. BOILER INSTALLATION	8
8. COOLING LOOP ASSEMBLY.....	9
10. ELECTRICAL DIAGRAM	10
11. HYDRAULIC DIAGRAMS	11
12. CONTROL UNIT	14
13. THE CONTROL UNIT' S BASIC SETTINGS	15
14. INSTALLATION MENU	17
14. THE CONTROL UNIT'S BASIC SETTINGS	20
15. IGNITING.....	20
16. OPERATION	20
17. ADDING FUEL.....	21
18. EXTINCTION	21
19. MAINTENANCE	21
20. RISK ANALYSIS	22
21. MEASURES IN CASE OF FAILURE.....	24
22. ENERGY EFFICIENCY.....	26
23. IDENTIFICATION MARKS.....	27
24. REGULATIONS AND STANDARDS.....	31
25. WASTE DISPOSAL.....	31
26. WARRANTY TERMS AND CONDITIONS	31
27. WARRANTY CARD	33
28. DECLARATION OF CONFORMITY	35
28. REGISTRATION CARD.....	36

1. INTRODUCTION

Dear Customer,

We appreciate that you have chosen a product from our product range and become one of our customers. We hope that you are content with our product. We hope that our product serves you reliably and for a long time. All employees of our company contribute to this. Please read the operating instructions thoroughly and please do not hesitate to ask any questions that you may have, we will be happy to advise you on the boiler's operation.

2. BOILER CHARACTERISTICS

The H4xx EKO-D series steel hot water boiler is designed and surface-treated for floor and central heating of family houses or suitable production plants with a maximum hydrostatic heating water height of 20 m. The H4xx EKO-D boiler is designed for solid fuel combustion, i.e., pieces of wood. Combustion of other substances or materials is not permitted. The boiler must be connected to a chimney corresponding to the boiler output and with the required minimum draft according to the operating instructions.

For proper boiler operation, in addition to expert installation, care must be taken to ensure that the boiler is properly serviced and regularly cleaned, as described below in these Instructions. This boiler was certified by the Engineering Test Institute in Brno according to ČSN EN 303-5 and meets the strictest criteria for solid fuel combustion as it is classified in the highest emission class and also meets the Ecodesign standard. This means that it is possible to apply for subsidies for these boilers.

The boiler is operated at underpressure at the flue gas outlet thanks to an exhaust fan which sucks air through the primary and secondary air dampers into the filling shaft, nozzle, heat exchanger and then into the flue gas path. The boiler operates under non-condensing conditions so there are no flue gas path requirements from the operation that would require protection against air condensation.

3. TECHNICAL DESCRIPTION

The H4xx EKO-D boilers are gasification boilers designed for wood burning. There is a refractory nozzle inside the boiler that transmits the flame into the back of the boiler, the heat exchanger and then into the chimney. Exhaust fan is located at the outlet of the boiler flue, ensuring ideal combustion under almost all conditions. This is controlled by a boiler control unit located in its back section.

Combustion air supply is provided by primary flaps (on the left and right sides of the boiler) and secondary flap (front of the boiler). The primary flaps ensure the correct boiler output and the secondary flap regulates the residual oxygen content in the boiler to optimise combustion with the lowest carbon monoxide and nitrogen oxide emissions.

The filling and cleaning doors are on the front of the boiler. Make sure that they are closed tightly during the boiler's operation. Wood combustion in gasification boilers generates a large amount of smoke which accumulates in the filling chamber under the filling door during the combustion process and gradually leaves through the nozzle into the heat exchanger. Do not open any of the doors during the burning process until there is only a small burning layer of remaining wood in the boiler, on which you can then refill the new fuel. More about heating in chapters 'Igniting', 'Operation', 'Adding Fuel', 'Extinction'.

You will find a pull rod on the side of the boiler that controls the exhaust flap to ensure that the smoke is drawn from the hopper so that no smoke escapes into the room when the door is opened. Do not open the door during the burning process, it is better to wait until the wood is burned to the residual hot layer that does not smoke. Then simply open the door and add more fuel. See 'Adding Fuel' for more information.

The filling chamber's side walls are fitted with cover plates to protect the boiler walls from harmful substances created during combustion. These cover plates are removable, but they must always be placed in the boiler during the burning.

There is a combustion chamber under the refractory nozzle. This is where the flame from the filling chamber goes down where the entire combustion process is completed. The combustion chamber is lined with fireclay bricks that capture and burn residual

amount of dust particles that would otherwise end up in the air. The combustion chamber can be accessed by opening the lower door. This way, you will also sweep the remaining ash out of the boiler.



All doors must be closed during boiler operation. If you leave any of the doors unsealed, flue gas leaks into the room, which can cause damage to health or property.

There is a boiler tube heat exchanger behind the combustion chamber, this is equipped with turbulators to reduce the chimney temperature and the amount of dust particles in the air. The boiler's design is simple, but it still meets the strictest criteria of emission standards.

4. TECHNICAL PARAMETERS

Technical parameters		Boiler type	Boiler type	Boiler type	Boiler type
Item name	Unit	H435 EKO-D	H442 EKO-D	H449 EKO-D	H455 EKO-D
Rated heat output	[kW]	35	42	49	55
Efficiency	[%]	89.5	89.1	90.0	90.0
Required chimney draft	[mbar]	0.19	0.17	0.18	0.18
Weight	[kg]	510	510	570	570
Ecodesign		Yes	Yes	Yes	Yes
Boiler class according to ČSN EN 303-5		5	5	5	5
Water volume	[litre]	145	145	161	161
Flue diameter	[mm]	130	130	130	130
Fuel consumption	[kg/hour]	8.9	10.8	12.5	14.2
Heating water temperature range	[°C]	65–85	65–85	65–85	65–85
Fuel shaft volume	[litre]	170	170	201	201
Filling space dimensions (HxW)	[cm]	40 x 45	40 x 45	40 x 45	40 x 45
Maximum log length	[cm]	53	53	53	53
Burning time at nominal output	[hour]	> 4	> 4	> 4	> 4
Flue gas temperature at nominal heating output	[°C]	133	153	140	143
Maximum heating water pressure	[MPa]	0.2	0.2	0.2	0.2
Heating water test pressure	[MPa]	0.4	0.4	0.4	0.4
Warranty fuel		Wood – A, dry wood with a calorific value of 15–17 MJ/kg, diameter 80–150 mm and humidity 12–20%			
Flue gas mass flow	[kg/s]	0.0246	0.0293	0.031	0.0327
CO at 10% O ₂	[mg/m ³]	200	91	-	174
Dust at 10% O ₂	[mg/m ³]	16	30	-	50
IP code	IP	20	20	20	20
Rated electrical input	[W]	44	42	42	42
Maximum electrical input	[W]	52	52	52	52
Standby input power	[W]	4	4	4	4
Recommended buffer tank size *[1]	[litre]	1000	1000	1000	1000
Voltage supply	[V/A/Hz]	230/2/50	230/2/50	230/2/50	230/2/50
Boiler hydraulic loss at Δ T = 20 K	[mbar]	5.556	7.989	7.761	7.533
Boiler hydraulic loss at Δ T = 10 K	[mbar]	22.18	31.21	28.64	26.07
Noise emission	dB	42.3 ± 3.2 dB			

*[1] The actual size of the buffer tank must be calculated by the designer.



Fuel consumption is directly dependent on the quality and type of fuel used, as well as maintaining the cleanliness of the internal heat exchange surfaces of the boiler. The smaller the chopped wood, the greater the boiler output, but the burning time per one filling is shortened. Conversely, if we need less power, we can use thicker wood to extend burning time per one filling. The position of the primary and secondary air flaps and the speed of the fan also affect the burning time.

Boiler dimensions:

		H435 EKO-D	H442 EKO-D	H449 EKO-D	H455 EKO-D
Outlet/inlet sleeve (male thread)		G1 1/4'	G1 1/4'	G1 1/4'	G1 1/4'
Cooling loop connection (female thread)		G 1/2'	G 1/2'	G 1/2'	G 1/2'
Draining and filling connection (female thread)		G 1/2'	G 1/2'	G 1/2'	G 1/2'
Power controller mounting connection (female thread)		G 3/4'	G 3/4'	G 3/4'	G 3/4'
A – total boiler height	[mm]	1411	1411	1551	1551
B – total boiler depth	[mm]	1283	1283	1323	1323
C – boiler width	[mm]	670	670	670	670
D – flue location	[mm]	607	607	607	607
E – water inlet location	[mm]	102	102	102	102
F – water outlet location	[mm]	1324	1324	1324	1324
G – cooling loop location	[mm]	628	628	768	768
J – location of drain valve	[mm]	97	97	97	97
Boiler body wall thickness (water/flame)	[mm]	5	5	5	5
Boiler body wall thickness (water)	[mm]	3	3	3	3

Boiler parts description:

Position	Part name
1	Main switch
2	Ashpan door
3	Filling door
4	Cleaning door
5	Exhaust fan
6	Operating unit
7	Control unit
8	Secondary air regulation
9	Primary air regulation
10	Chimney flap control
11	Cleaning hole
12	Cooling loop
13	Refractory nozzle
14	Turbulator (H416, H420EKO-D 1x; H425EKO-D 2x)
15	Cleaning flap
16	Smoke flap

17	Filling shaft spacers
18	Filling shaft
19	Combustion chamber
20	Front cover

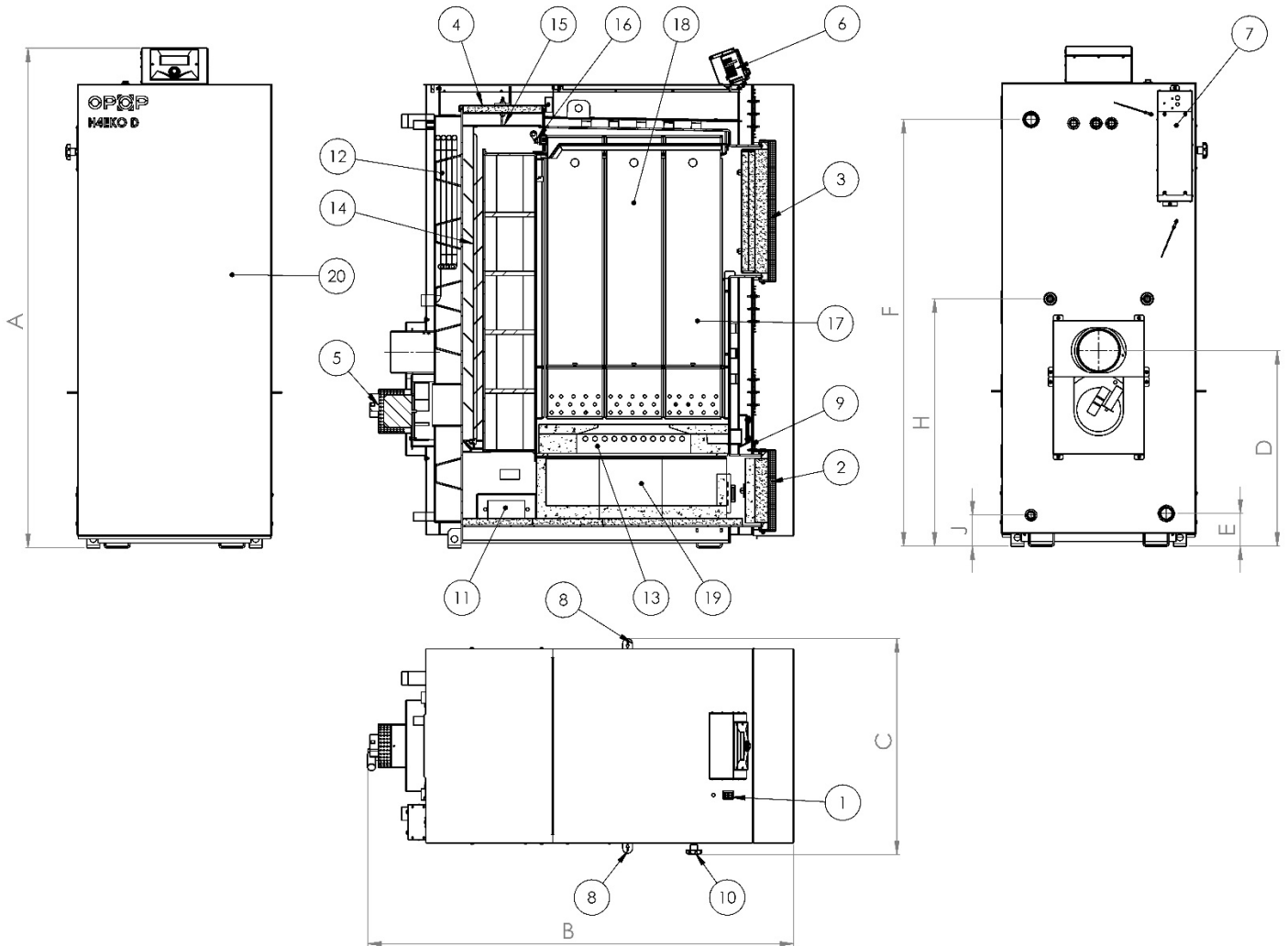

Front part of the boiler:

- Control unit
- Secondary air flap
- Ashpan door

Back part of the boiler:

- CH sensor sink
- STB safety sensor sink
- Heated water outlet
- Flue

Left side of the boiler:

- Primary air flap
- Exhaust flap pull rod for adding fuel
- Cleaning closure at the bottom of the boiler

Right side of the boiler:

- Primary air flap
- Cleaning closure at the bottom of the boiler
- Sink for electric heater at the bottom of the boiler

- Flue gas temperature sensor
- Exhaust fan
- Cooling loop inlet and outlet (interchangeable)
- Cooling loop sensor sink
- Cold water inlet
- Filling valve inlet

Top side of the boiler:

- Filling door
- Cleaning door cover
- Cleaning door
- Protection plate under the cleaning door



Stops are located on all primary and secondary air flaps to prevent the complete closing of air supply to the boiler. Therefore, it's not possible to extinguish the boiler by closing the flaps to the limit position, which is not permissible according to standards.

5. LIST OF REPLACEABLE SPARE PARTS

The complete disintegration of all parts of the H4xx-D series boilers can be found below. Use this list to identify the boiler parts when ordering or replacing them.

7. BOILER INSTALLATION

The solid fuel boiler may only be installed by a company with a valid authorisation to install it or by authorised personnel from our company. The list is available at opop.cz or you can request it by telephone at 571 675 589. An installation project must be prepared according to the valid regulations.

Boiler placement

The boiler must be installed in a separate boiler room, specially adapted for heating. The boiler room must have sufficient space for installation and boiler maintenance. Sufficient circulation of fresh air for combustion must be ensured, the chimney design must ensure adequate draft for the type of boiler and must be in accordance with the construction criteria set forth in these Instructions and in the binding regulations. Never install the boiler in open spaces or balconies, in areas occupied by people such as kitchen, living room, bathroom, bedroom, in areas where explosive and flammable materials are present.

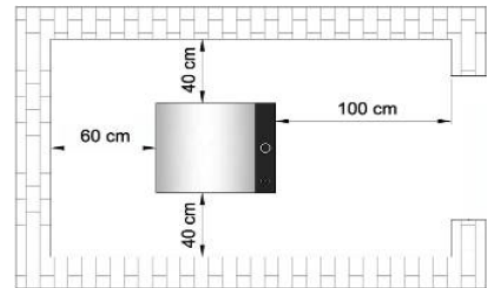

Install the boiler on a concrete base made of flame retardant material or on a fireproof substrate.

There should be free space around the boiler visible in the figure on the right. During the boiler's installation and operation, a safe distance of 200 mm from the flammable materials of flammability class B, C₁ and C₂ (according to ČSN 06 1008) must be observed.

For lightly flammable materials of flammability class C₃, which quickly burn and burn themselves after removing the ignition source (e.g., paperboard, cardboard, bitumen and tar paper, wood and fibreboard, plastics, floor coverings), the safety distance doubles to 400 mm.

The safe distance must also be doubled if the flammability class of the building material is not proven.

Heating system pipes installation

There are welded water inlet and outlet with diameter G1 ¼" in the back part of the boiler. These pipes can also be fitted with old-type flanges if you change our old boiler to a new one and you do not want to change the pipes to connect to the boiler. In such a case, the boiler's dimensions fit to the heating circuit to which our old-type H4v or H4eko boiler was connected. Please inform us or your local retailer about the possibility of buying these flanges if you change the boiler from one of the old-type ones.

The hot water system must be designed in accordance with ČSN 06 0310:2006 (Central heating, design and installation), ČSN 06 0830: 2006 (Safety devices for central heating and domestic hot water), ČSN 07 7401 (Water and steam for thermal energy devices with operating steam pressure up to 8 MPa), ČSN EN 303-5 (Central heating boilers – Part 5: Solid fuel boiler with manual or automatic fuel supply, rated at maximum 300 kW).



The boiler must be installed in combination with the buffer tank.

Drain valve installation

A ½" nozzle is welded to the boiler at the back of the boiler, into which the drain valve is screwed. After filling the system with water, it is necessary to close the valve!

Chimney connection

The boiler may only be installed to the chimney according to ČSN 73 4201:2002. The connection of the hot water boiler must only be carried out with the approval of a chimney sweep organisation.

The boiler must be connected to a separate chimney flue which has sufficient draft for virtually any operating conditions.



The chimney draft is always lower at the time of increased humidity, mist and the heated chimney head on which the hot sun has been shining for a long time.

The flue path piping mounted on the boiler must be firmly assembled and mounted to prevent accidental or spontaneous release. We recommend that the flue from the boiler to the chimney is no longer than 1 m and that it rises towards the chimney; recommended slope of at least 5% (3°). The connection is recommended to be direct – no more than one bend.

The boiler and flue must comply with the fire regulations ČSN 06 1008:1997 (Fire safety of heating equipment), ČSN EN 13501-1:2007 (Fire classification of construction products and building elements – Part 1: Classification using data from reaction to fire tests) and may be installed at a safe distance of 400 mm from flammable materials. The safe distance must also be observed when the flammability class of a flammable substance is not proved.

8. COOLING LOOP ASSEMBLY

The H4xx EKO-D boiler is in accordance with the requirements of ČSN EN 303-5:2013 and Government Decree No 26/2003 Coll., equipped with a safety heat exchanger to remove excess heat, which must ensure that the maximum water temperature in the boiler, i.e., 110 °C, is not exceeded. This safety heat exchanger is designed to be controlled at the inlet by a safety drain valve. This valve can be ordered from us at any time so that the installation on the cooling loop is as simple as possible.

Operation principle

Insert the safety valve sensor into the sink on the upper side of the boiler. The sensor reads the boiler water temperature. If the boiler water temperature increases to 95°C (TS 130), the boiler automatically opens and discharges water into the built-in heat exchanger to remove heat and prevent the boiler from overheating. After the boiler's water has cooled down, the valve automatically closes until it stops the cold water inflow to the safety heat exchanger. This activity can be repeated several times, depending on the amount of fuel in the filling shaft or on the duration of reduced heat consumption through the heating system.

- The drain relief valve must always be connected to the water inlet to the cooling loop so that the cooling loop is not under constant service water pressure
- If the recommended cooling loop connection to the boiler in accordance with the operating instructions is not adhered to, the cooling loop may be pressurised and consequently cause leaks.
- For the valve's correct operation, it must be ensured that the valve is connected to a permanent cooling water source of at least 2 bar (preferably a public water supply) at a temperature of around 15°C
- Check the correct valve function annually at minimum



10. ELECTRICAL DIAGRAM

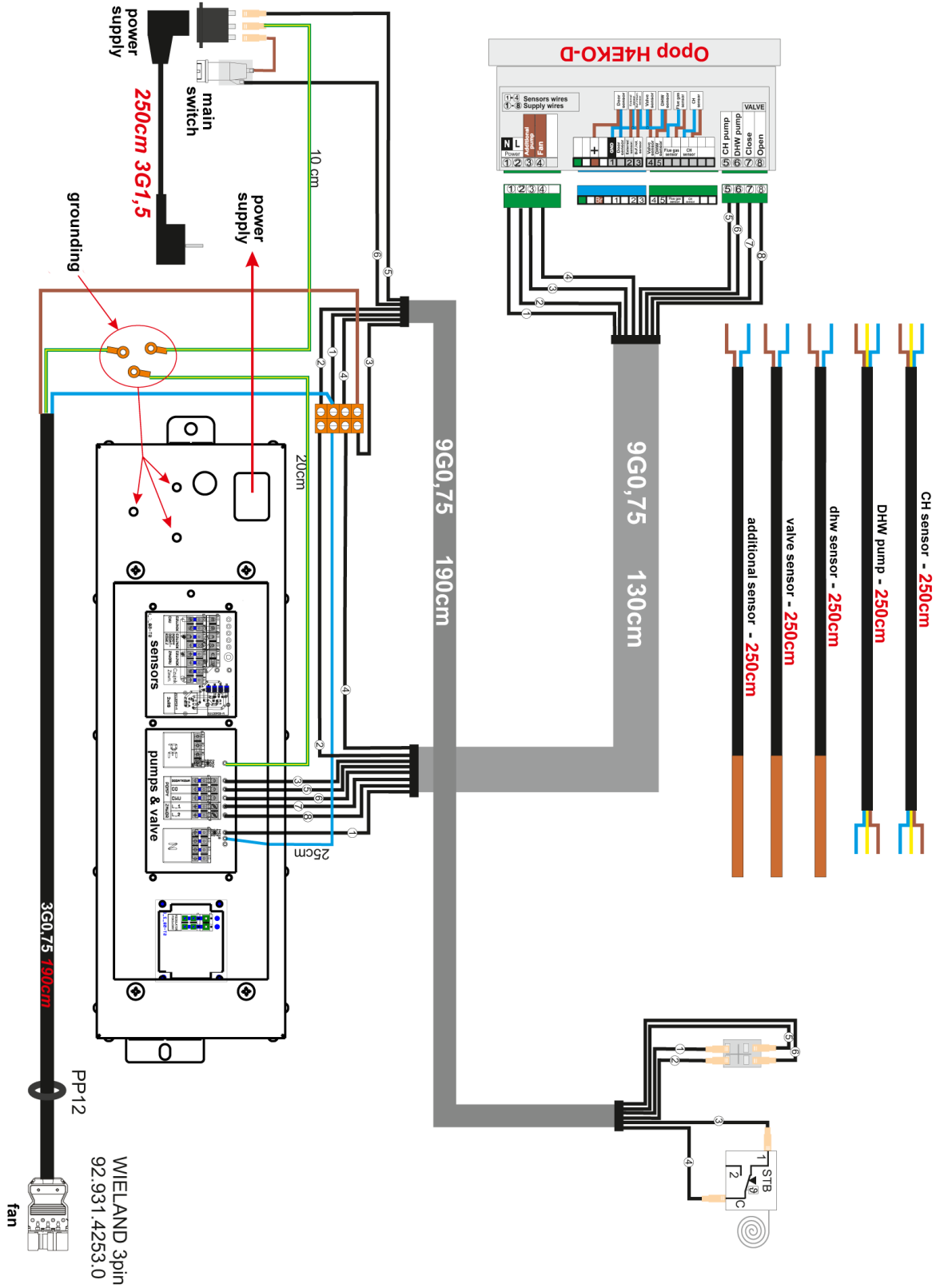

11. HYDRAULIC DIAGRAMS

CONNECTION WITH 1 HEATING CIRCUIT, MIXING VALVE, BUFFER TANK

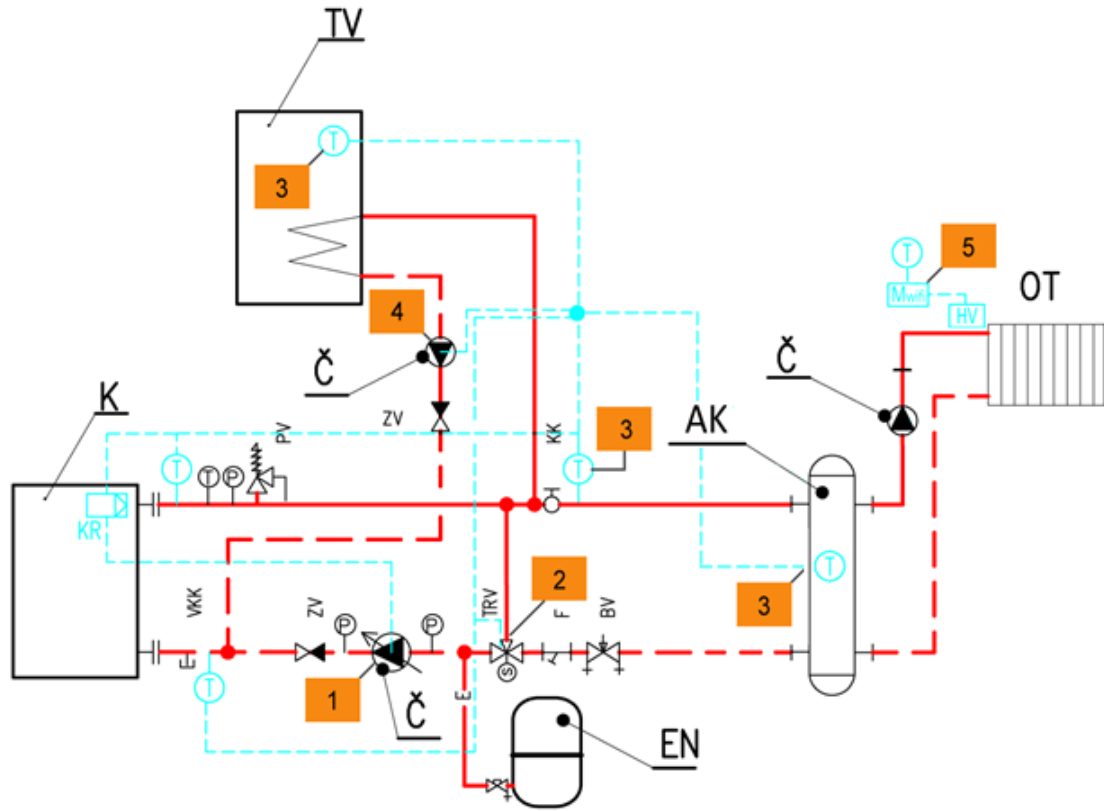

No	Part	Type / Component / Description	Electrical connector	Order number
1	CH pump	Primary circuit pump	CH pump	-
2	Mixing valve 1	3- or 4-way mixing valve (connected to 431N module)	Valve	-
3	KTY temperature sensors	KTY mixing valve 1 sensor	Valve sens.	34571800020
		KTY hot water sensor	DHW sens.	
		KTY buffer tank sensor	Buffer sens.	
4	DHW pump	Domestic hot water pump	DHW pump	-
5	Wireless radiator head control	Wifi8 module (for 1 building)	-	358120400020
		Wifi8 zone sensor (for 1 zone / room), (1 module = up to 8 zones / rooms)	-	358120400040
		Wifi8 valve head (for 1 radiator), (1 zone = up to 6 heads)	-	358120400030

PIPING LEGEND		DEVICE LEGEND		FITTINGS LEGEND	
	HEATING WATER SUPPLY PIPE 75/55°C	K	Automatic pellet boiler	KK	BALL VALVE
	RETURN HEATING WATER PIPES 75/55°C	ZP	Pellet hopper	F	FILTER
	EXPANSION PIPE	TV	Indirect fired hot water cylinder	TRS	HW THERMOSTATIC TEMPERATURE CONTROLLER
	SOLAR CIRCUIT FEED PIPE	Č	Circulator pump for heating water	ZV	Non-return valve
	SOLAR CIRCUIT RETURN PIPE	EN	Expansion vessel	PV	CHECK VALVE
	EXPANSION PIPE	HVDT	HYDRAULIC DYNAMIC PRESSURE EQUALISER	BV	BALANCING VALVE
		SK	SOLAR COLLECTOR	T	THERMOMETER
		ŠČ	SOLAR CIRCULATOR PUMP	P	PRESSURE GAUGE
		EN-S	SOLAR EXPANSION VESSEL	VKK	DRAIN BALL VALVE
		OT	HYDRAULIC CIRCUIT FOR HEATING ELEMENTS	SUR	BALL VALVE WITH LOCKING FOR EN
		PDL	HYDRAULIC CIRCUIT FOR FLOOR HEATING		

CONNECTION WITH 1 HEATING CIRCUIT, MIXING AND THERMOSTATIC VALVE, BUFFER TANK

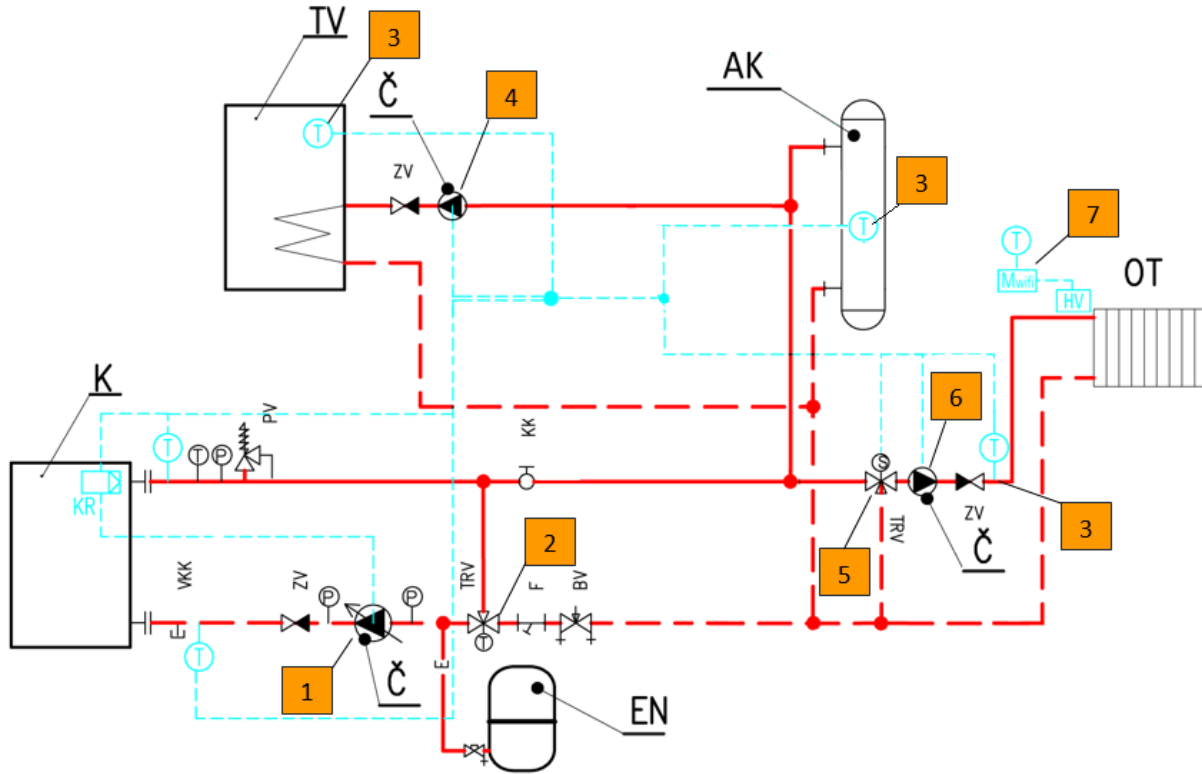

No	Part	Type / Component / Description	Electrical connector	Order number
1	CH pump	Primary circuit pump	CH pump	-
2	Thermostatic valve	3-way thermostatic valve	-	-
3	KTY temperature sensors	KTY mixing valve 1 sensor	Valve 1 sens.	345718000020
		KTY hot water sensor	DHW sens.	
		KTY buffer tank sensor	Buffer sens.	
4	DHW pump	Domestic hot water pump	DHW pump	-
5	Mixing valve 1	3- or 4-way mixing valve	Valve 1	-
6	Valve 1 pump	Pump	Valve pump	-
7	Wireless radiator head control	Wifi8 module (for 1 building)	-	358120400020
		Wifi8 zone sensor (for 1 zone / room), (1 module = up to 8 zones / rooms)	-	358120400040
		Wifi8 valve head (for 1 radiator), (1 zone = up to 6 heads)	-	358120400030

PIPING LEGEND		DEVICE LEGEND		FITTINGS LEGEND	
	HEATING WATER SUPPLY PIPE 75/55°C	K	Automatic pellet boiler	KK	BALL VALVE
	RETURN HEATING WATER PIPES 75/55°C	ZP	Pellet hopper	F	FILTER
	EXPANSION PIPE	TV	Indirect fired hot water cylinder	TRS	HW THERMOSTATIC TEMPERATURE CONTROLLER
	SOLAR CIRCUIT FEED PIPE	Č	Circulator pump for heating water	ZV	Non-return valve
	SOLAR CIRCUIT RETURN PIPE	EN	Expansion vessel	PV	CHECK VALVE
	EXPANSION PIPE	HVDT	HYDRAULIC DYNAMIC PRESSURE EQUALISER	BV	BALANCING VALVE
		SK	SOLAR COLLECTOR	T	THERMOMETER
		SČ	SOLAR CIRCULATOR PUMP	P	PRESSURE GAUGE
		EN-S	SOLAR EXPANSION VESSEL	VKK	DRAIN BALL VALVE
		OT	HYDRAULIC CIRCUIT FOR HEATING ELEMENTS	SUR	BALL VALVE WITH LOCKING FOR EN
		PDL	HYDRAULIC CIRCUIT FOR FLOOR HEATING		

12. CONTROL UNIT



1. House heating – Indicator of heating type. This can be divided into the following types:
 - a. House heating – Only the central heating (CH) pump is active
 - b. DHW priority – The DHW pump is activated as a priority; after the set DHW temperature has been reached, the DHW pump is deactivated and the CH pump is activated to ensure water circulation in the primary circuit
 - c. Parallel – The DHW and CH pumps work simultaneously. Once the set DHW temperature has been reached, the DHW pump is deactivated and the CH pump is working to ensure water circulation in the primary circuit.
 - d. Summer mode – Only the DHW pump is active.
2. Current date, room thermostat indication, flue gas temperature.
3. The entered and actual temperature of the central heating measured at the back of the boiler on the boiler outlet water pipe.
4. Indication of current fan speed.
5. Boiler status
6. Indication of the CH pump operation
7. Indication of the DHW pump operation
8. Indication of the auxiliary pump operation
9. Indication of activation of the master mixing valve
10. Indication of the opening of the mixing valve when connected and activated.
11. Navigation key for entry and navigation in the menu.
12. Exit the menu, cancel the selection.

13. THE CONTROL UNIT'S BASIC FUNCTIONS

The control unit controls the water circulation (CH) pump, the domestic hot water (DHW) pump, the secondary circuit circulation pump, the mixing valve, the buffer tank and the exhaust fan.

It is also possible to control two additional mixing valves using the 431N modules. With this type of controller, the fan speed is determined by measuring the boiler temperature and the flue gas temperature measured at the boiler outlet. The fan operates continuously and its speed depends directly on the actual boiler temperature, flue gas temperature and the difference of these parameters in relation to the specified temperature.

1. Homepage

During the controller's normal operation, the homepage is displayed on the graphic display. Depending on the current operating mode, the corresponding display panels are displayed. Pressing the impulse controller moves the user to the menu's first level. The display shows the first four options of this menu.

Display the next options by rotating the impulse controller. To select a function, press the impulse controller. Changing the parameters is done in a similar way. To make a change, you need to confirm it. This is achieved by pressing the impulse controller at the word CONFIRM.

Press CANCEL if you do not want to make any changes to the function. Use the EXIT button to exit the menu. ATTENTION: Standby mode does not turn off the controller's power supply.

2. Igniting / Extinction

With this function, the user can easily ignite/extinguish the boiler. After the initial filling and igniting of the fuel, select the *Igniting* function, which automatically controls the fan. After the optimal parameters of the central heating and flue gas temperatures have been reached, the boiler switches to the operating mode smoothly. After the boiler has switched to operating mode, the display will show *Work* instead of *Igniting*.

From now on, the option performs the fan on/off function. With this function, we can turn the fan on/off at any time for a certain period of time.

3. Screen view

With this function, the user can select one of four views of the main controller operation panels:

- CH panel screen (shows the current boiler operating mode),
- main valve (shows the main valve's operating parameters),
- valve 1 (shows the operating parameters of additional valve 1),
- valve 2 (shows the operating parameters of additional valve 2).

ATTENTION: In order for the valve parameters panels to be active, these valves must be installed and configured correctly by the specialist.

4. Temperature settings

Here you can select the desired temperature of the boiler's outlet water 'CH temperature' and the required boiler temperature 'DHW temperature' if the DHW heating is activated in the 'Operating modes' menu.

4.1 Set CH temperature

This option allows you to set the set boiler temperature. The boiler temperature can be changed by the user from 45°C to 85°C. It is also possible to change the set CH temperature directly in the controller's homepage by turning the impulse controller.

4.2 Set DHW temperature

This option allows you to set the temperature of the domestic hot water. The user can change this temperature from 30°C to 60°C.

5. Manual mode

For user convenience, the controller is equipped with Manual mode. In this function, each operating device (fan, CH pump, DHW pump, additional pump – circulation or valve) is switched on and off independently of each other and each active mixing valve can be closed, opened or stopped in the given position.

Pressing the impulse controller will start the function of the selected device. The device will be operated until pressing the impulse button.

In addition, the user has the option to set any fan speed in the Fan output option in the manual mode.

6. Pump operating modes

In this function, one of the four boiler operating modes is activated according to the user's requirements.

- **House heating** – In this option, the controller enters the CH heating mode. The pump will start operating above the pump switch-on temperature (factory set to 38°C). The pump stops running below this temperature (minus hysteresis 2°C).
- **Boiler priority** – In this mode, the boiler pump (DHW) is first turned on and operates until the set DHW temperature has been reached. Once it is reached, the DHW pump is switched off and the CH pump is activated. The CH pump runs all the time until the DHW temperature drops below the set temperature by the DHW hysteresis value. Then the CH pump switches off and the DHW pump switches on (the pumps run alternately). In this mode, the fan and feeder operation is limited by a maximal boiler temperature to 62°C to prevent the boiler from overheating.

ATTENTION: The boiler must have check valves installed on the circulation of the CH and DHW pumps. The valve on the DHW pump prevents the hot water from being sucked out.

- **Parallel pumps**

In this mode, both pumps start operating simultaneously when the pump switch-on temperature is reached. This temperature can be different for each pump, depending on the setting by the user. This means that one pump can be switched on before the other, but when the two set temperature limits are exceeded, the pumps will run simultaneously. The CH pump is operating continuously and the DHW pump switches off after the set DHW temperature has been reached; on the contrary, it will be switched on when the temperature falls below the set temperature reduced by the set DHW hysteresis value.

- **Summer mode**

In this option, the CH pump is switched off and the DHW pump switches on when the set switch-on temperature is reached. It will operate continuously until the temperature drops to the switch-on temperature reduced by the DHW hysteresis value or if this condition is met: $(\text{boiler temperature}) + 2^{\circ}\text{C} \leq (\text{DHW temperature})$.

In the summer mode, only the set boiler temperature is set, which is also the set DHW temperature.

7. Time settings

Select the current time so that the functions that work with the current time work properly.

8. Date settings

Select the current date so that the functions that work with the current date work properly.

9. Installation menu

All fixtures that are connected to the boiler are activated and adjusted there. See the next chapter of these Instructions for a description of the Installation menu.

10. Language choice

Use this function to select the language version of the controller.

11. Factory settings

The controller is factory adjusted to be operational. However, it is necessary to adapt the settings to the specific operating conditions and needs. It is possible to return to the factory settings at any time. Selecting the factory settings clears the boiler setting values entered by the user (written in the menu) in favour of the settings entered by the boiler manufacturer. From this point on, the user can re-set their own parameters.

12. Programme information

With this function, the user can verify the programme version of the controller.

13. Display settings

Changing the display brightness and the power saving mode, i.e., the time after which the display brightness decreases so that it is not excessively worn.

14. INSTALLATION MENU

1. Valve settings, built-in valve

Activation and adjustment of the mixing valve. The supply voltage of the valve is 230V. Connection to the 'Valve' output in the boiler control unit.

- **Valve status, On/Off** – This function allows the valve to be temporarily taken out of service.
- **Set temperature on the valve** – This setting sets the temperature in circulation maintained by the mixing valve.
- **Temperature control** – This parameter determines the frequency of measurement (control) of the temperature of the water downstream of the valve in the CH or DHW installation. If the sensor detects a temperature change (deviation from the set temperature), then the electric valve opens or closes by the necessary distance to reach the set temperature again.
- **Opening time** – This function sets the time for the valve's full opening, i.e., the time needed to open the valve from 0% to 100%. This time must be determined in accordance with the valve servo motor used (indicated on the data plate).
- **Valve type** – Use this option to select the type of valve: CH or floor. This setting will change the maximum possible temperature that can be set on the valve.
- **Unit stroke** – This function determines the percentage unit stroke for opening the valve, i.e., by a maximum of what percentage the valve can be opened or closed at one time (maximum valve movement in one measurement cycle).
- **Minimum opening** – This function sets the valve's minimum opening value. The valve will not close below this value.
- **Equithermal regulation** – This function requires the installation of an outdoor sensor. The sensor must be positioned in such a way that it is not exposed to direct sunlight and other undesirable atmospheric effects. In order for the valve to work properly, the set temperature (after the valve) is determined for four possible outdoor temperatures.
- **Return protection** – The valve can keep the return water to the boiler above the specified limit. Until this is exceeded, the valve is closed. After reaching the minimum return water temperature, the valve opens and adjusts its position according to the set temperature on the valve.
- **Boiler protection** – If the CH temperature is exceeded above the specified limit in this function, the mixing valve opens and releases overheated water into the heating system to protect the boiler from high temperature.
- **Opening direction** – Select the valve's opening direction according to the electrical connection of the 2 phases of the valve in the boiler control unit.
- **Valve pump setting** – This function allows the user to select the pump operating mode. The pump is switched on:
 - *Always* (the pump operates continuously, independently of temperature);
 - *Above the switch-on limit* (the pump switches on above the set switch-on temperature). If the pump is to be switched on above the switch-on limit, it is necessary to determine the temperature of the pump switch-on limit (boiler temperature, measured on the CH sensor).

- **Valve type** – This function allows the user to set the boiler protection against water that is too cold returning from the main circulation (water returning from the heating system to the boiler), which can cause low-temperature corrosion of the boiler. The return protection works in such a way that if the return water temperature is too low, the valve is closed until the short circulation of the boiler reaches the corresponding temperature. The function also protects the boiler from dangerously high return temperature by preventing boiling water. When this function is enabled, the user sets the minimum and maximum permissible return temperature.
- **Room regulation reduction** – This function is only active in cooperation with the room controller (standard or RT10). After the room controller reaches the set temperature in the apartment (it indicates room heating), the valve closes to lower the temperature behind the valve by the temperature set in this function.
- **OPOP (RT10) controller operation** – This option is active only in cooperation with the OPOP (RT10) room controller and allows to choose an option of the controller's cooperation with the mixing valve:
 - *Temperature reduction* – in this mode the RT10 room controller, after heating the apartment to the set temperature, reduces the set temperature of the valve by the value of Room regulation reduction.
 - *Dynamic changes* – in this mode, the RT10 room controller, after heating the apartment to the set temperature, works according to the following settings:
- **Set valve temperature change** – This setting determines how much the valve temperature decreases or increases when the room temperature changes per unit. The function is closely related to the Room temperature difference parameter.
- **Temperature control** – How often the position of the valve is adjusted based on the change in the current temperature on the valve.
- **Calibration** – Calibration of the valve so that the unit records the limit positions on the valve. The valve opens and closes automatically. Wait for the calibration to complete and then continue to adjust other valve functions if necessary.
- **Room temperature difference** – This setting determines the unit change in the current room temperature (within 0.1°C) at which the above-described change in the valve temperature occurs.

Example:

Setting: Room temperature difference 0.5°C

Setting: Changing the set valve temperature of 1°C

Setting: Set valve temperature 40°C

Setting: Set room controller temperature 23°C

Case 1: If the room temperature rises to 23.5°C (by 0.5°C), the valve closes at the set temperature of 39°C (by 1°C).

Case 2: If the room temperature drops to 22°C (by 1°C), the valve is set to the set temperature of 42°C (by 2°C).

2. **Valve settings, Valve 1 and 2** – This function allows the user to select settings for the operation of the additional mixing valve. In order for the valve to work properly and in accordance with the user's requirements, it is necessary to configure it by setting the relevant parameters (similar to the main valve). The detailed setting of the additional valves is provided in the instructions for the 431N module which allows the control of these additional valves.
3. **Temperature reduction by thermostat** – If the room thermostat is activated, this item can be used to adjust by how many degrees the set CH temperature of the boiler should be reduced to reduce the boiler output or deactivate the fan to achieve this reduced CH temperature.
4. **GSM module** – The GSM module is an additional device cooperating with the boiler controller, which enables remote control of the boiler operation using a mobile phone. The user is notified by an SMS message about a possible boiler controller alarm and by sending the corresponding SMS, the user is informed about the current temperature of all sensors. Once the authorisation code is entered, it is also possible to remotely change the entered temperatures.

Refer to the GSM module instructions for detailed settings.
5. **Internet module** – Use of this operating mode is possible only after the purchase and connection of the S T-500 additional control module, which is not part of the controller's standard equipment. An Internet module is a device that allows the user to control the boiler's operation remotely over the Internet or the local network. The user checks the status of all installed boiler components on the computer or telephone. The operation of each device is shown in the form of an animation.

Refer to the Internet module instructions for detailed settings.

- 6. Room thermostat** – With this function the user can select the corresponding type of room controller. The user may select between standard controller (traditional two-position) and OPOP/TECH (RT10) controller.

When the OPOP/TECH controller is connected, the user has the possibility to control and change the set CH, DHW and mixing valve temperatures. All boiler controller alarms are also displayed. When working with the mixing valve, the user can see the current outdoor temperature on the display panel with valve parameters.

ATTENTION: No external voltage must be connected to the outputs of the room controller. Otherwise, the controller may be destroyed.

- *CH pump control* – after the room controller signals heating, the CH pump is switched off.
- *Boiler control* – after the room controller signals reaching the heating temperature, the temperature drops to the set temperature.

- 7. Operation algorithm** – Activation or deactivation of PID mode. In PID mode, the boiler unit modulates the fan speed. The closer the temperature is to the set temperature, the lower the speed of the fan. If the PID mode is deactivated, then the fan only runs at a fixed speed without modulation. Once the CH temperature is reached, the fan is deactivated.

- 8. Parameters of the AKU tank** – Heating of the accumulation tank is carried out by means of a temperature sensor inserted into the sink in the buffer tank. If the buffer tank heating is activated, the corresponding temperature sensor must also be connected, otherwise there will be an alarm message.

- a. *Set temperature* – Enter the desired temperature in the buffer tank measured by the temperature sensor.
- b. *DHW function* – If the hot water cylinder is connected to the system and this is controlled by the DHW pump connected to the boiler unit, you can choose whether to use this DHW heating in the case of a heated buffer tank. Depending on the hydraulic connection, we recommend consulting with the installer.

- 9. Pump switch-on temperature** – This option is used to set the switch-on temperature of the CH pump (it is the temperature measured at the water outlet from the boiler) and the DHW pump. The pump starts to work above this temperature. Pump is switched off after the boiler temperature drops below the switch-on temperature (minus hysteresis 2°C).

- 10. DHW hysteresis** – This option is used to set the hysteresis of the set DHW temperature. It is the maximum difference between the set temperature (i.e., the selected DHW temperature at which the pump shuts off) and the temperature at which it starts working again.

Example:

The set temperature is 55°C and the hysteresis is 5°C.

Upon reaching the set temperature of 55°C, the DHW pump is switched off and the CH pump is switched on.

When the temperature drops to 50°C, the DHW pump is switched on again.

- 11. Auxiliary pump** – The user has the option of connecting an auxiliary pump: circulator or valve pump. Depending on the pump selection, the settings need to be configured correctly.

The user here sets the daily cycle and pump breaks for 30 minutes. To facilitate setting these parameters, there is a possibility of copying the selected time interval to other days. Once the operating plan has been established, it is necessary to set the working time and pump shutdown time during the activity in the previously selected time interval. If necessary, it is also possible to quickly erase the current settings, thus making it easier to set new time intervals.

- 12. Rotary switch sensitivity** – With this setting we can determine the impulse controller's sensitivity, which detects the correct fan speed and protects it against damage, in levels from 1 to 3 (where 1 means the highest sensitivity).

- 13. External sensor calibration** – Correction of the outdoor sensor is performed during installation or after a longer operating time of the controller if the displayed temperature differs from the actual one. Control range: -10 to +10°C.

- 14. Boiler DHW disinfection** – Thermal disinfection involves raising the temperature to the required disinfection temperature, i.e., at least 60°C throughout the DHW circulation. The purpose of DHW disinfection is the destruction of Legionella pneumophila, which causes a weakening of the immunity of the organism.

After switching this function on (only in boiler priority mode), the boiler will heat until the disinfection temperature specified by the user has been reached. The disinfection time parameter specifies the duration of the disinfection (e.g.: 10 minutes). After that, the boiler returns to normal operating mode.

Once the disinfection is switched on, the disinfection temperature must be reached until the disinfection time is reached. Otherwise, the function is automatically deactivated.

- 15. Factory settings** – Resets the installation menu items to factory settings.
- 16. PID supervision** – In case of reaching the set CH temperature, the boiler enters the so-called supervision mode. In this mode, the fan is deactivated to prevent power build-up. Attention: The boiler must be installed with a buffer tank so as not to overheat the water in the heating system and the boiler.
- 17. Display contrast** – Change of the font saturation on the boiler control unit display.

14. THE CONTROL UNIT'S BASIC SETTINGS

When commissioning the boiler, it's necessary to select the correct boiler output. The power is set by the technician installing the boiler in the control unit's Service Menu. Ensure that the boiler output is set correctly so that the fan speed matches your boiler output.

The maximum boiler temperature can be set by pressing the navigation key and selecting 'CH temperature'. This temperature will be maintained by the boiler and the fan will be deactivated after the CH temperature is reached.



Boiler performance is affected by external factors such as chimney draft, primary and secondary flaps, fan speed, fuel type, correct or incorrect power output calculated by the designer. Therefore, the set CH temperature may be exceeded. For this reason, it's necessary to install it with a buffer tank.

The maximum DHW temperature, if DHW heating is activated, can be set by pressing the navigation key in the 'DHW temperature' item. You activate the DHW heating in the 'Pump operating modes' settings. If you activate the DHW heating, make sure that the DHW sensor is connected, otherwise there will be an alarm message.

15. IGNITING

The wood in the boiler burns out through the refractory nozzle. Place small pieces of wood and chips on the nozzle so that the nozzle is permeable and the flame can pass through the nozzle. Use a paper or a solid ignitor for igniting. Press 'Igniting' in the menu and the fan will be activated. The ideal fan speed for igniting is in the range of 20 to 40%. Higher fan speed may cause the flame to blow out.

Now it's necessary to wait for the wood to start burning and then close the filling door. The boiler will automatically enter the 'Operation' mode after reaching the chimney temperature above 45°C. When this happens, confirm the transition to the 'Operation' mode with the navigation key. The boiler will now work to achieve the set CH temperature by modulating the fan speed.

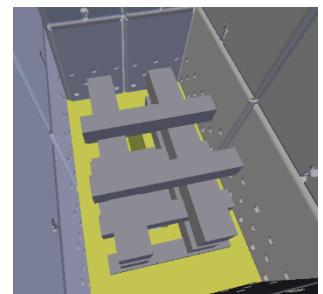

Proper placement of wood for igniting

16. OPERATION

In operation, the boiler is controlled according to the CH temperature you set, and also the flue gas temperature. If the flue gas temperature drops below 45°C, the display shows the request for adding fuel.

The fan operates until the set CH temperature is reached. Then, the fan will be deactivated. The boiler temperature may continue to rise, depending on the chimney draft and the opening of the primary air flaps.

The correct primary and secondary air flap settings is indicated by a line above the flap rod. This setting ensures the required boiler output and ideal combustion emissions.

If you want the fuel in the boiler to burn longer, the primary air rod on the side of the boiler can be closed more. The flaps can never be fully closed, as the burning fuel always requires at least a minimum air supply for proper combustion.



During combustion, there is accumulation of fumes in the filling shaft. Therefore, never open the filling door during burning. Wait for the chimney temperature to drop below 45°C, leaving only the hot layer that forms the smallest amount of smoke in the filling chamber. After that, then you can add more fuel.

The primary air flaps on the side of the boiler affect the boiler output. The figure shows the setting to achieve the desired boiler output. By closing the flaps, you reduce the boiler output and extend the burning time. The position of the flaps must be identical on both sides, otherwise the wood in the filling chamber will burn unevenly.

O – open flap position Z – closed flap position (still allows air supply to the boiler)

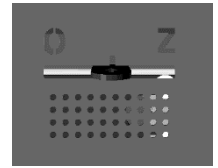

The secondary air flap is located in the front of the boiler. It blows combustion air directly into the nozzle and improves the quality of fuel and gas combustion. The flap's ideal position is indicated by a line above the flap rod. There is no need to change the flap position during burning. In general, if you close the primary flaps, you can close the secondary flap at the same proportion so that the combustion quality is as good as possible. While in the closed position, the flap still allows air to be drawn into the nozzle.

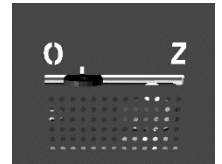

17. ADDING FUEL

Fuel is added to the boiler at a time when only a hot layer of wood remains in the filling shaft and all large pieces are burned. It happens according to the current flue gas temperature displayed at the top right of the display. The standard combustion temperature is above 100°C. If the flue gas temperature drops below about 50°C, only the hot layer remains in the boiler and the boiler is ready for adding new fuel inside.

Before opening the filling door, move the suction flap rod to the open position and wait for 20 seconds. Opening the flap ensures that the residual smoke is drawn directly into the chimney. After that, the filling door can be opened slightly to see if all the smoke is sucked out and then open the door slowly.

Add new fuel onto the hot layer. Use gloves because the hot layer is really hot. After adding the wood, close the filling door and remember to move the suction flap rod to the closed position.



Never leave the suction flap rod in the open position during the boiler operation. Otherwise, the fuel in the filling shaft will burn upwards, not through the nozzle. This may cause damage to the metal parts in the filling shaft or damage to the suction flap. Not to mention that all of your heat would have fled to the chimney before it was transferred to the water.

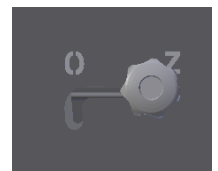

18. EXTINCTION

The boiler is extinguished when the flue gas temperature drops below 45°C and the user does not add more fuel. The fan stays in the deactivated position, there is the Extinction word shown on the display.

The boiler can be extinguished manually at any by entering 'Extinction' in the menu. This will deactivate the fan but be careful – if there is still fuel in the filling shaft, it will still burn according to the natural chimney draft. Similarly, combustion products will still accumulate in the boiler. Therefore, even after extinguishing, when opening the door, follow the instructions in the Adding fuel section. If you open the filling door too quickly without an open suction flap, the smoke will escape into the room.

19. MAINTENANCE

The boiler must be cleaned regularly. Not only the filling shaft and combustion chamber, but also the heat exchanger. Follow the instructions below to keep your boiler in the best possible condition.

1. Filling shaft: Open the filling door and move the residual ash through the nozzle to fall down into the combustion chamber or vacuum it out using an ash vacuum. Clean the side shield plates in the filling shaft with a scraper if necessary.

2. Combustion chamber: Open the bottom door and remove all the ash from the combustion chamber. Check the correct position of all fireclay bricks before closing to prevent the stopping of exhaust fumes flowing from the combustion chamber to the boiler heat exchanger.
3. Boiler heat exchanger: Remove the cleaning door at the top of the boiler. You'll find a shielding flap below them, which you also remove. Now you can clean the heat exchanger walls using a scraper and brush supplied with the boiler. The residual ash falls to the bottom of the heat exchanger under the boiler dividers. This ash can either be vacuumed using an ash vacuum with a longer extension so that you get under the dividers. If you do not have an ash vacuum, use cleaning openings on both sides of the boiler to remove residual ash from the bottom of the heat exchanger; see point 4.
4. Cleaning opening: There is a small cover at the underside of the boiler (left and right), which serves to remove ash that falls under the heat exchanger. Remove the cover sheet first on the boiler's side casing, then unscrew the 2 wing nuts to remove the metal plate. Using a cleaning tool, remove the ash out onto a shovel or use a vacuum cleaner.
5. Exhaust fan: Before the season, we recommend unscrewing the exhaust fan and removing the ash that has accumulated behind the fan in the spiral cabinet. Carefully wipe the fan propeller with a brush and check its attachment, it must not wobble. If it is not firmly attached, tighten the lock nut that holds the propeller on the fan shaft.

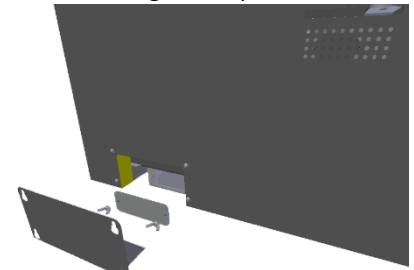

Cleaning opening on the sides



After cleaning, be sure to restore the boiler to its original state. Close all the doors, screw the cleaning opening back in, tighten the fan in an airtight manner and make sure all the components (firebricks, cover plates in the filling shaft, turbulators, shielding flap) are in the right place.

20. RISK ANALYSIS

Residual risks and their prevention. The risks arising from the boiler's operation under conditions of foreseeable use and reasonably foreseeable misuse have been minimised by available technical means. Despite the design and technical measures implemented, certain residual risks resulting from the risk analysis that are given by the technological process during the different phases of the device's life remain in the boiler operation.

These are risks that particularly that arise from the boiler operator's inattention and non-compliance with safety rules during operation. To further reduce the risks and ensure greater safety efficiency, note the possible occurrence of certain residual risks that cannot be eliminated by any technical solution.

Risks when supplying the boiler and its accessories		
Source of risk	Effects of risk	Hazard elimination
Transport means – lorry, technician's passenger car	Restrictions on the movement of workers (neighbours, family members) and machines at the place where the equipment will be unloaded from a lorry or car	Pre-define the unloading area and draw attention of the employee (neighbours, family members) to this fact
Handling truck, forklift truck, lorry arm or other means by which the equipment will be moved	There is a risk of injury or damage being caused by parts of the equipment that are being moved	Thoroughly consider the strategy of unloading and transporting individual parts of the equipment to the place where the equipment is temporarily stored or assembled
Equipment storage, whether in an assembled or dismantled state	Collisions of people, machines, vehicles, etc. with stored parts of the equipment. Water condensation in the wiring and consequent injury to the technician or damage to the equipment	Mark the storage space appropriately or secure and mark it where appropriate. The area must be dry so that moisture does not get into the wiring

Risks when placing the boiler at a designated location and assembling it		
Source of risk	Effects of risk	Hazard elimination
Handling truck, forklift truck or other means by which the equipment will be moved	There is a risk of injury or damage being caused by parts of the equipment that are being moved	Take extra caution if your staff or you are to help our technicians
Assembly	Injuries caused by a drill, angle grinder and common tools that technicians will use. For example, hammer, screwdriver, file, etc. Fall of one of the equipment components.	If your staff or you help our technicians, have proper protective equipment. For example, safety goggles, work gloves, etc. Be extremely cautious during the entire work
Risks in normal mode of the boiler and its accessories		
Source of risk	Effects of risk	Hazard elimination
Boiler body	Burns by hot door (filling, cleaning, ashpan) when opened, hand or face burns at the moment of opening	Only open doors with protective gloves, the doors are in direct contact with flue gases and can reach temperatures up to 400°C. Open the door so that any escape of hot flue gases does not hit any part of the body. The danger takes a few seconds before the pressure inside combustion chamber becomes stable
Combustion chamber	Hand injuries, burns from hot firebricks. Removal of ash from the combustion chamber.	Only handle the firebricks in protective gloves intended for this purpose and in the cold state of the firebricks. Only dump ash at designated locations. The ash may still be hot so only store it at designated locations
Risk during maintaining the boiler and its accessories		
Source of risk	Effects of risk	Hazard elimination
Combustion chamber	Burns, inhalation of dust, eye contact with dust	If the boiler is not shut down for a long time, its parts may be still hot, so use protective gloves. When cleaning the combustion chamber, use goggles and a respirator. The recommended downtime is 4 hours.
Thermal risks		
The boiler must not be exposed to higher operating pressure than prescribed		
It's forbidden to overheat the boiler		
The boiler must be protected against low-temperature corrosion by appropriate connection with automatic return temperature valve		
Only the prescribed fuel can be burned in the boiler		
It's forbidden to store combustibles near the boiler		
Risks associated with fuel handling		
Particulate matter is emitted when handling the fuel. Therefore, the operator should use appropriate protective equipment according to the degree of dustiness		
Since this is a fuel, the relevant fire regulations must be followed and a suitable fire extinguisher must be available		
Ergonomic risks		
The boiler must be in a horizontal position in the boiler room		
All doors, lids and cover must be properly closed during boiler operation		

21. MEASURES IN CASE OF FAILURE

Alarm message	Description
Damaged flue gas sensor	Automatic igniting is not possible because the transition between igniting and operation is based on the flue gas temperature. You can ignite the boiler manually in Manual mode. Check for an adequate connection of the flue gas sensor or, if the connection is OK, replace the sensor.
Damaged buffer tank sensor	The buffer tank sensor is a KTY type. Check the buffer tank sensor connection. Be careful when extending the sensor cable. The standard resistance at room temperature is 2 kΩ. If you extend the sensor too much, the resistance characteristic changes and an alarm message occurs. Replace the sensor if the connection and resistance characteristics are OK.
Damaged CH sensor	The boiler output water sensor is a KTY type. Check its connection. Replace the sensor with a new one if the connection is OK.
Damaged DHW sensor	The DHW sensor is a KTY type. Check the DHW sensor connection. Be careful when extending the sensor cable. The standard resistance at room temperature is 2 kΩ. If you extend the sensor too much, the resistance characteristic changes and an alarm message occurs. Replace the sensor if the connection and resistance characteristics are OK.
Damaged MOSFET sensor 1 MOSFET temperature too high	The MOSFET transistor is the component responsible for changing the speed of the exhaust fan. The standard temperature on this component does not exceed 50°C. If the temperature is too high, there will be an alarm message. Check the exhaust fan's operation, remove it, clean it and try again. If the problem persists, call the OPOP service.
Damaged equithermal valve sensor Damaged outdoor sensor of built-in valve	If you connect an outdoor temperature sensor, it is possible to control the mixing valve equithermally. To adjust the set temperature on the valve according to the outside temperature. Before activating this function, make sure that the outdoor sensor is properly connected. Otherwise, an alarm message will occur. If the sensor cable is too long it can cause a change in resistance characteristics and an alarm message can occur.
Damaged valve return sensor	The return sensor is a KTY type. Check the return sensor connection. Be careful when extending the sensor cable. The standard resistance at room temperature is 2 kΩ. If you extend the sensor too much, the resistance characteristic changes and an alarm message occurs. Replace the sensor if the connection and resistance characteristics are OK.
Damaged valve sensor	If you activate the mixing valve, make sure the valve sensor is connected. Otherwise, an alarm message will occur. Be careful when extending the sensor cable. The standard resistance at room temperature is 2 kΩ. If you extend the sensor too much, the resistance characteristic changes and an alarm message occurs. Replace the sensor if the connection and resistance characteristics are OK.
Failed igniting	The maximum ignition phase time is 30 minutes. If the flue gas temperature does not exceed 80°C or the CH temperature does not exceed 40°C by that time, an alarm message will occur.
Module not found	If the boiler is connected to the Internet via opop.emodul.eu, it may happen that the connection to the router is not detected during registration. In this case, make sure that the Internet cable connection is OK, that you are registering according to the instructions. If problems persist, ask your ISP to unlock the communication port 2000 on your router or call the OPOP service.
Temperature does not rise Temperature does not increase	If the boiler is in operation for more than 30 minutes and the CH temperature has not exceeded the minimum limit by that time, an alarm message will occur. Make sure that the boiler is filled with water, that the CH sensor is properly positioned in the water inlet on the back of the boiler. Alternatively, call the OPOP service.
Floor temperature too high	If you activate an additional pump, one of this pump's functions is floor heating. Before activating the additional pump, first connect the sensor. The sensor is a KTY type. Be careful when extending the sensor cable. The standard resistance at room temperature is 2 kΩ. If you extend the sensor too much, the resistance characteristic changes and an alarm message

	occurs. Replace the sensor if the connection and resistance characteristics are OK.
Disconnected safety thermostat	If the room thermostat is activated but is not connected, this error state will be announced. Make sure that the thermostat is properly connected, functional and connected to the power supply.
Incorrect fan Fan: Damaged bearings Fan: Blowing shaft obstruction	If a higher current consumption is generated on the fan, this alarm message may occur. Check the fan's cleanliness and proper fan propeller attachment. The propeller must not be deformed in any way. Check the area of the spiral cabinet behind the exhaust fan, which must be clean and without ash deposition. Also check the operation of the fan, no grind can be heard. If the problems persist, call the OPOP service.
No communication with Internet No communication with GSM No communication with thermostat	If any of these accessories are activated but not physically connected, an alarm message will occur. Check for correct connection and accessory settings. Alternatively, call the OPOP service.
Low fuel level	In the event of a flue gas temperature drop, information regarding the empty filling shaft is displayed. This happens when the flue gas temperature drops below 48°C in the Operation mode. At this time, it's possible to add new fuel to the hot layer. If the temperature drops even more, below 35°C, Extinction will be announced and the boiler (fan) switches off.
Valve 1 temperature too high	If the temperature on the mixing valve is higher than 85°C, an alarm message will occur. Ensure that the boiler is properly connected to ensure that its output corresponds to the heat loss of the building. In accordance with the law, the boiler must be operated with a buffer tank to store excess heat.
CH temperature too high	The maximum CH temperature is controlled by two sensors, namely the CH sensor (KTY type) and the STB sensor (safety sensor). Both sensors are located at the back of the boiler. If the CH temperature exceeds 85°C, the CH sensor will sound an alarm. If the CH temperature continues to rise, the fan power is deactivated by means of the STB safety sensor at a temperature above 90°C. In this case, after cooling the boiler, it is necessary to press the button on the STB sensor at the back of the boiler to put the boiler back into operation. Make sure that the system and the boiler have water, the pumps work properly and the boiler is installed with the buffer tank according to the law. Alternatively, call the OPOP service.

- In terms of safety and economy of operation, the appliance must be operated according to the Instructions.
- The boiler may be left unattended, provided that the power is set so that it cannot overheat the system (reduced operation) or if it is equipped with a regulated and operable combustion air draft controller, however, the operator must check it occasionally.



During operation, some parts of the boiler (filling, cleaning and ashpan doors, flue) can be heated to a higher temperature, causing burns when touched. Therefore, use the protective gloves included in the accessories.

- The boiler may only be operated by adults who are familiar with these Instructions. Keeping children unattended near the appliance is inadmissible.
- It's forbidden to use flammable liquids for igniting in the appliance and in any way increase its rated output (thermal overload) during operation.
- The user may only carry out routine maintenance or replace spare parts. Do not interfere with the boiler design, change its function or leave the damaged product in operation.

Certainly, during the first and even subsequent heating intervals, excessive air condensation on the boiler surfaces may occur; a dark fluid may appear in the ashpan section. This is due to the low water temperature in the boiler (below the condensing point of 65°C) and the low flue gas temperature. The condensing will cease after partial settling of combustion products on the walls and after igniting above 65°C. This is not a boiler leak. Each boiler is thoroughly tested with overpressure and the possibility of leakage is virtually eliminated.

The boiler is tarred:

- At low chimney draught. If it is permanently low, it is removable only by a structural modification. If it is temporarily low, it is due to weather conditions
- With wet fuel
- When the reduced operation is permanent at a low temperature below the air condensing point of the flue gas, i.e., 65°C
- Incorrect boiler size due to heat losses of heated space
- In case of improper handling.



When burning wet or damp fuel, nominal output may not be achieved, the boiler becomes excessively clogged, covered with dew and tarred. This results in considerable economic losses, which are reflected in increased fuel consumption and reduced boiler life.

There are several important principles that need to be observed to ensure that the boiler function is safe and economical.

- Operator's conscientiousness
- Adequate chimney draft
- Clean boiler (draughts and vents)
- Tight boiler – properly installed and sealed cleaning, filling and ashpan door
- Correct boiler output selection for a given heated building
- Properly dried fuel

AVERAGE WOOD MOISTURE CONTENT IN %

Drying time	Yard wood stored in bulk		Yard wood stored under a protective roof 3 months after cutting	50 cm long logs, stored under a protective roof 3 months after chopping	50 cm long logs, stored under a protective roof immediately after chopping
	G	K	G K	K	K
0*	75	78	76,78	78	76
3 months	48	62	48,61	61	40
6 months	37	46	32,45	35	29
9 months	33	38	27,37	28	28
1 year	36	35	26,33	27	27
1.5 years	18	27	18,21	17	16
2 years	16	24	16,17	14	13
2.5 years	15	24	15,18	14	13

*Initial humidity K - round logs G - quarter logs

22. ENERGY EFFICIENCY

I	II	III	IV	V	VI
Supplier's name or trade mark	Supplier's model identifier	Energy efficiency class	Rated heat output in kW	Energy efficiency index	Seasonal space heating energy efficiency in %
OPOP s.r.o.	H435 EKO-D	A+	35	114	77
OPOP s.r.o.	H442 EKO-D	A+	42	113	77

OPOP s.r.o.	H449 EKO-D	A+	49	115	78
OPOP s.r.o.	H455 EKO-D	A+	55	115	78

23. IDENTIFICATION MARKS

Model identification mark: H435 EKO-D									
Condensing boiler:		No	Solid fuel co-generation boiler:		No	Combined boiler:		No	
Fuel adding mode: Manual		Manual: The boiler should be operated with a DHW cylinder of at least x (*) litres / Automatic: It is recommended that the boiler be operated with a DHW cylinder of at least x (**) litres							
Fuel				Preferred fuel (one only):		Other suitable fuel:			
Wood logs, moisture content ≤ 25%				Yes		No			
Wood chips, moisture content 15–35%				No		No			
Wood chips, moisture content > 35%				No		No			
Pressed wood in the form of pellets or briquettes				No		No			
Sawdust, moisture content ≤ 50%				No		No			
Other wood biomass				No		No			
Non-wood biomass				No		No			
Bituminous coal				No		No			
Lignite (including briquettes)				No		No			
Coke				No		No			
Anthracite				No		No			
Fossil fuel briquettes				No		No			
Other fossil fuel				No		No			
Briquettes from biomass (30–70%) and fossil fuels				No		No			
Other mix of biomass and fossil fuels				No		No			
Features when using the preferred fuel:									
Seasonal indoor space heating energy efficiency η_s [%]:				77					
Energy efficiency index (EEI):				114					
Energy efficiency class:				A+					
Name	Designation	Value	Unit	Name	Designation	Value	Unit		
Useful heat output				Useful efficiency					
At rated heat output	Pn(***)	35.0	kW	At rated heat output	η_n		%		
At [30%] rated heat output if applicable	Pp	Not relevant	kW	At [30%] rated heat output if applicable	η_p	Not relevant	%		
Solid fuel co-generation boilers: Electrical efficiency				Auxiliary electricity consumption					
At rated heat output	$\eta_{el,n}$		%	At rated heat output	e _{lmax}		kW		
				At [30%] rated heat output if applicable	e _{lmin}	Not relevant	kW		
				Built-in secondary emission reduction device if applicable		Not relevant	kW		
				In standby mode	PSB		kW		
Contact details		OPOP s.r.o., Zašovská 750, Valašské Meziříčí, 757 01							
(*) Tank volume = $45 \times Pr \times (1 - 2.7/Pr)$ or 300 litres, whichever is higher; Pr expressed in kW									
(**) Tank volume = $20 \times Pr$; Pr expressed in kW									
(***) For preferred fuel, Pn equals Pr									

Model identification mark: H442 EKO-D							
Condensing boiler:	No	Solid fuel co-generation boiler:	No	Combined boiler:	No		
Fuel adding mode: Manual	Manual: The boiler should be operated with a DHW cylinder of at least x (*) litres / Automatic: It is recommended that the boiler be operated with a DHW cylinder of at least x (**) litres						
Fuel		Preferred fuel (one only):		Other suitable fuel:			
Wood logs, moisture content $\leq 25\%$		Yes		No			
Wood chips, moisture content 15–35%		No		No			
Wood chips, moisture content $> 35\%$		No		No			
Pressed wood in the form of pellets or briquettes		No		No			
Sawdust, moisture content $\leq 50\%$		No		No			
Other wood biomass		No		No			
Non-wood biomass		No		No			
Bituminous coal		No		No			
Lignite (including briquettes)		No		No			
Coke		No		No			
Anthracite		No		No			
Fossil fuel briquettes		No		No			
Other fossil fuel		No		No			
Briquettes from biomass (30–70%) and fossil fuels		No		No			
Other mix of biomass and fossil fuels		No		No			
Features when using the preferred fuel:							
Seasonal indoor space heating energy efficiency η_s [%]:			77				
Energy efficiency index (EEI):			113				
Energy efficiency class:			A+				
Name	Designation	Value	Unit	Name	Designation	Value	Unit
Useful heat output				Useful efficiency			
At rated heat output	Pn(***)	42.0	kW	At rated heat output	η_n		%
At [30%] rated heat output if applicable	Pp	Not relevant	kW	At [30%] rated heat output if applicable	η_p	Not relevant	%
Solid fuel co-generation boilers: Electrical efficiency				Auxiliary electricity consumption			
At rated heat output	$\eta_{el,n}$		%	At rated heat output	elmax		kW
				At [30%] rated heat output if applicable	elmin	Not relevant	kW
				Built-in secondary emission reduction device if applicable		Not relevant	kW
				In standby mode	PSB		kW
Contact details			OPOP s.r.o., Zašovská 750, Valašské Meziříčí, 757 01				
(*) Tank volume = $45 \times Pr \times (1 - 2.7/Pr)$ or 300 litres, whichever is higher; Pr expressed in kW							
(**) Tank volume = $20 \times Pr$; Pr expressed in kW							
(***) For preferred fuel, Pn equals Pr							

Model identification mark: H449 EKO-D							
Condensing boiler:	No	Solid fuel co-generation boiler:	No	Combined boiler:	No		
Fuel adding mode: Manual	Manual: The boiler should be operated with a DHW cylinder of at least x (*) litres / Automatic: It is recommended that the boiler be operated with a DHW cylinder of at least x (**) litres						
Fuel		Preferred fuel (one only):		Other suitable fuel:			
Wood logs, moisture content $\leq 25\%$		Yes		No			
Wood chips, moisture content 15–35%		No		No			
Wood chips, moisture content $> 35\%$		No		No			
Pressed wood in the form of pellets or briquettes		No		No			
Sawdust, moisture content $\leq 50\%$		No		No			
Other wood biomass		No		No			
Non-wood biomass		No		No			
Bituminous coal		No		No			
Lignite (including briquettes)		No		No			
Coke		No		No			
Anthracite		No		No			
Fossil fuel briquettes		No		No			
Other fossil fuel		No		No			
Briquettes from biomass (30–70%) and fossil fuels		No		No			
Other mix of biomass and fossil fuels		No		No			
Features when using the preferred fuel:							
Seasonal indoor space heating energy efficiency η_s [%]:				78			
Energy efficiency index (EEI):				115			
Energy efficiency class:				A+			
Name	Designation	Value	Unit	Name	Designation	Value	Unit
Useful heat output				Useful efficiency			
At rated heat output	Pn(***)	49.0	kW	At rated heat output	η_n		%
At [30%] rated heat output if applicable	Pp	Not relevant	kW	At [30%] rated heat output if applicable	η_p	Not relevant	%
Solid fuel co-generation boilers: Electrical efficiency				Auxiliary electricity consumption			
At rated heat output	$\eta_{el,n}$		%	At rated heat output	elmax		kW
				At [30%] rated heat output if applicable	elmin	Not relevant	kW
				Built-in secondary emission reduction device if applicable		Not relevant	kW
				In standby mode	PSB		kW
Contact details		OPOP s.r.o., Zašovská 750, Valašské Meziříčí, 757 01					
(*) Tank volume = $45 \times Pr \times (1 - 2.7/Pr)$ or 300 litres, whichever is higher; Pr expressed in kW							
(**) Tank volume = $20 \times Pr$; Pr expressed in kW							
(***) For preferred fuel, Pn equals Pr							

Model identification mark: H455 EKO-D							
Condensing boiler:	No	Solid fuel co-generation boiler:	No	Combined boiler:	No		
Fuel adding mode: Manual	Manual: The boiler should be operated with a DHW cylinder of at least x (*) litres / Automatic: It is recommended that the boiler be operated with a DHW cylinder of at least x (**) litres						
Fuel				Preferred fuel (one only):		Other suitable fuel:	
Wood logs, moisture content $\leq 25\%$				Yes		No	
Wood chips, moisture content 15–35%				No		No	
Wood chips, moisture content $> 35\%$				No		No	
Pressed wood in the form of pellets or briquettes				No		No	
Sawdust, moisture content $\leq 50\%$				No		No	
Other wood biomass				No		No	
Non-wood biomass				No		No	
Bituminous coal				No		No	
Lignite (including briquettes)				No		No	
Coke				No		No	
Anthracite				No		No	
Fossil fuel briquettes				No		No	
Other fossil fuel				No		No	
Briquettes from biomass (30–70%) and fossil fuels				No		No	
Other mix of biomass and fossil fuels				No		No	
Features when using the preferred fuel:							
Seasonal indoor space heating energy efficiency η_s [%]:				78			
Energy efficiency index (EEI):				115			
Energy efficiency class:				A+			
Name	Designation	Value	Unit	Name	Designation	Value	Unit
Useful heat output				Useful efficiency			
At rated heat output	Pn(***)	55.0	kW	At rated heat output	η_n		%
At [30%] rated heat output if applicable	Pp	Not relevant	kW	At [30%] rated heat output if applicable	η_p	Not relevant	%
Solid fuel co-generation boilers: Electrical efficiency				Auxiliary electricity consumption			
At rated heat output	$\eta_{el,n}$		%	At rated heat output	elmax		kW
				At [30%] rated heat output if applicable	elmin	Not relevant	kW
				Built-in secondary emission reduction device if applicable		Not relevant	kW
				In standby mode	PSB		kW
Contact details		OPOP s.r.o., Zašovská 750, Valašské Meziříčí, 757 01					
(*) Tank volume = $45 \times Pr \times (1 - 2.7/Pr)$ or 300 litres, whichever is higher; Pr expressed in kW							
(**) Tank volume = $20 \times Pr$; Pr expressed in kW							
(***) For preferred fuel, Pn equals Pr							

24. REGULATIONS AND STANDARDS

ČSN 06 0310 – Central heating. Design and assembly.

ČSN 06 0830 – Safety devices for central heating and service water heating

ČSN 06 1008 – Fire safety of local appliances and heat sources (heaters up to 50 kW)

ČSN 06 1610 – Flue parts of home appliances.

ČSN 07 0245 – How water and low-pressure steam boilers. Hot water boilers up to 50 kW.

Technical requirements:

ČSN 07 7401 – Water and steam for thermal energy devices with operating excess pressure up to 8Mpa

ČSN EN 13 501-1+A1 – Classification of construction products and structures.

Part 1: Classification in accordance with the fire reaction tests.

ČSN 73 0831 – Fire safety of constructions. Gathering areas.

ČSN 73 4201 – Chimneys and flues. Design, implementation and connection of fuel appliances.

ČSN 73 4210 – Implementation of chimneys and flues and connection of fuel appliances

ČSN EN 303-5 – Solid fuel boilers for central heating

163/2002 Coll. – Government Decree

26/2003 Coll. – Government Decree

185/2001 Coll. – Waste Act

477/2001 Coll. – Packaging Act

34/1996 Coll. – Consumer Protection Act

25. WASTE DISPOSAL

Packaging materials (paper and wood) can be burned in the boiler. PP tape, unburned remains and ash shall be disposed of as communal waste. At the end of the boiler's life, dispose of its body and grates as metal waste. Insulation material shall be taken to an appropriate collection point.

Wooden laths are designed for one-time use and cannot be reused as such. Their removal is governed by Act No 185/2001 Coll., on waste and amending certain other acts, as amended. Used packaging material complies with the requirements for packages specified by Act No 477/2001 Coll., on packages and amending certain other acts, as amended.

26. WARRANTY TERMS AND CONDITIONS

The following points must be met not only in order to meet the warranty terms and conditions, but also to ensure correct installation in terms of applicable standards, safety and ensuring the boiler's smooth operation.

1. The OPOP boilers may only be installed by a company with a valid authorisation to carry out such installation and maintenance. An installation project must be prepared according to the valid regulations.
2. The heating system must be filled with water that meets the requirements of ČSN 07 7401 and especially its hardness must not exceed the required parameters. The use of antifreeze mixtures is not recommended by the manufacturer.
3. Connecting the boiler to the system must be done in accordance with applicable regulations and standards.
4. The boiler must be connected to the chimney vent according to ČSN 73 4201:1989.
5. The flue gas path must be checked by a chimney sweep before installing the boiler. Require an inspection report covering the basic parameters of the flue gas path, including the chimney diameter, its length and chimney draft.

6. The flue should not be longer than one metre and should be fitted with a cleaning opening. The flue can only be longer if the chimney draft has been measured and registered not further than 30 cm from the boiler and if it meets the minimum operating draft; see the Technical Parameters chapter.
7. The OPOP boiler must be installed in a separate boiler room, specially adapted for heating. The boiler room must have sufficient space for the boiler's installation and maintenance. There must be sufficient circulation of fresh air for combustion.
8. Never install the boiler in open spaces or balconies, in areas occupied by people such as kitchen, living room, bathroom, bedroom, in areas where explosive and flammable materials are present.
9. Install the boiler on a concrete base made of fire-resistant material or on a surface with a support made of fire-resistant material.
10. A minimum handling space should be provided around the boiler, namely: 60 cm from the rear and from the sides, 100 cm from the front of the boiler and hopper.
11. When installing and operating the boiler, it's necessary to keep a safe distance of 200 mm from flammable materials. Do not place any flammable material at this distance or less from the boiler.
12. It is forbidden to store fuel behind the boiler or next to the boiler within a distance smaller than 800 mm.
13. It is forbidden to store the fuel between two boilers in the boiler room.
14. It is necessary to use only the guaranteed fuel specified in the instructions for a given boiler.
15. The manufacturer is not responsible for the quality of the fuel, in terms of combustion quality, ash quantity or the frequency of boiler cleaning due to the fact that these factors are affected only by external influences such as fuel quality, dust and moisture in the fuel, chimney draught or the correct setting of the combustion process.
16. It is forbidden to use flammable liquids (petrol, alcohol, etc.) for igniting in the boiler.
17. It is forbidden to overheat the boiler in any way during operation.
18. If there is a risk of flammable vapours or gases entering the boiler room or during works in which there is a temporary risk of fire or explosion (gluing of floor coverings, painting with flammable paints, etc.), the boiler must be shut down in time before the work begins.
19. The boiler, including the flue, must be thoroughly cleaned after the end of the heating season. The boiler room must be kept clean and dry.
20. It is forbidden to interfere with the boiler design and wiring.
21. The manufacturer is not responsible for damage caused by the product's improper adjustment or improper operation.
22. Parts subject to wear are not covered by the standard warranty period. These parts are understood as: ashpan rope seal, grenamine and fireclay plate. However, these parts perform their function for a long time if the boiler and its components are operated in accordance with the instructions.
23. The manufacturer is not responsible for the rust formed on the boiler and its components, as this is always and only due to external influences, such as humidity in the room, fuel or due to improper installation without protection of the boiler against low-temperature corrosion.
24. The boiler must be protected against low return water temperature by a valve that prevents cold water from entering the boiler. The minimum acceptable return water temperature is specified by the manufacturer at 55°C.
25. The manufacturer is not responsible for the condensation of cold air in the flue gas path, as this must be prevented by proper installation of the flue gas path and proper setting of the combustion process in the boiler.
26. The manufacturer is not responsible for the escape of smoke from the boiler into the room if it is caused by low chimney draught, improper installation of the boiler or incorrect setting of the combustion process or mechanical damage to the boiler components.
27. The manufacturer is not responsible for damage to parts caused by handling, transport, incorrect adjustment or improper use or other external fault which is not directly related to the function of individual components of the boiler.
28. The installation of the boiler, boiler attachments and its correct setting and start is always the installation company's responsibility who carried out the sale of the boiler to the end customer.

27. WARRANTY CARD**For the H435EKO-D, H442EKO-D, H449EKO-D, H455EKO-D hot water boilers****Manufacturer:** OPOP spol. s r.o., Valašské Meziříčí**Telephone:** 571 675 589, **fax.:** 571 611 225

Dispatch date from the plant: _____

The user is obliged to have a professional service company to put the equipment into operation, to conduct regular maintenance and repairs. This warranty card includes quality and completeness certificate. This warranty card shall contain a certificate of quality and completeness. The manufacturer confirms that the product has been inspected and that its design complies with the technical conditions and ČSN EN 303-5. We provide a quality, design and workmanship warranty for the boiler for the duration of 24 months from the date of its sale to the given consumer, but no longer than 30 months from the moment of releasing the product from production facility; under the warranty conditions, we will correct all defects demonstrably caused by faulty material, faulty design or faulty production as soon as possible and at our own expense, provided that:

- The boiler is in normal technical conditions pursuant to the Instructions and is operated pursuant to the Instructions.
- The boiler is connected to a chimney flue in accordance with ČSN 73 4201:1989
- The boiler has not been mechanically damaged by force (no unauthorised intervention has been conducted with the exception of interventions permitted in the Instructions)
- Chimney draft pursuant to ČSN 303-5 corresponds to the value stated in this standard (or the values specified in these Instructions according to the type of boiler)
- The customer, when exercising their warranty claim, submits this duly completed warranty card
- All manufacturer's instructions for using pressurised expansion containers are met
- If the consumer does not sell the product within the above stated warranty period, the consumer shall bear all responsibility for any product defect
- Expenses related to the processing of a warranty claim shall be covered by the consumer
- The filling door insulation and the fireclay place are considered consumables that cannot be covered by this warranty in case of damage

When reporting a defect, it's always necessary to present this warranty card, give the exact address and indicate the circumstances under which the defect occurred. The method and place of repair will be decided in our company.

TK on _____

Sold on _____

For a steel weldment – we guarantee its permanent tightness as standard for two years from the date of release from the production plant. The above-standard 60-month guarantee is guaranteed if the heating system has not used a pressurised expansion vessel, the required temperature range of the heating water is ensured and the leak is due to poor quality material or welding work. To accept the warranty claim of a leaking steel weldment, it must be clearly demonstrated that the water in the boiler has not formed due to condensation of cold air, but due to the leakage of the weldment. The warranty claim cannot be accepted in the event of faults caused by the operator or when the boiler is connected to a heating system that does not meet the basic operating conditions of the boiler. If the warranty claim is accepted within the extended warranty period, we will hand over the replacement weldment by LTL transport or personal collection of the user. If the defective weldment is not returned to the production plant within 30 days from the date of sending or handing over the replacement weldment, the user will be charged the full amount of the weldment, including the cost of transporting the new weldment.

The replaced weldment is covered by warranty of 24 months from the date of takeover within the extended warranty period, i.e., 60 months. The boiler weldment is sprayed with black, water-dilutable paint, which may result in peeling of this paint. The peeling paint does not affect the function of the boiler. This colour is burned after the first heating.

Complaint procedure:

1. Submit personally, by post or by email a confirmed warranty card with proof of payment for the product.
2. Report the exact address or telephone number and indicate the circumstances under which the event occurred.
3. The manufacturer's service technician shall notify the user of the product about the way of complaint settlement:
 - a) By sending the claimed part for replacement
 - b) In the event of impossibility of the procedure referred to in point (a), the manufacturer has the right to determine the method, date and performance of the repair by its service staff or contractor
 - c) The user is obliged to allow the manufacturer to make the repair according to point (b)
 - d) If the user does not allow access to perform the repair, the manufacturer considers this complaint to be terminated
 - e) If the defect cannot be repaired, the user has the right to a replacement of the defective part
 - f) In the event of unauthorised complaint, i.e., failure to confirm the defect or leakage of the weldment by the service staff, the claimant will be charged the costs associated with the inspection and travel expenses to the user
 - g) If it is necessary to expedite the complaint, contact the manufacturer's service staff on 571 675 252 or 727 876 463
 - h) In the case of sending a heavily soiled claimed boiler to the production plant, the production plant will carry out the cleaning and the user will be charged the costs associated with cleaning the boiler

28. DECLARATION OF CONFORMITY

28. REGISTRATION CARD

Dear Customer,

We are extremely pleased that you have decided to buy our product. This decision entitles you to a 20% discount on spare parts. In order to receive the above benefits, it is necessary to fill in the registration card and send it to our address:

OPOP spol s r.o.
Sales Department
Zašovská 750
757 01 Valašské Meziříčí

Upon receipt of the completed form, we will immediately send you the Customer Card, which entitles you to receive discounts on spare parts from the manufacturer. It is always necessary to communicate your Customer Card number when ordering spare parts.

Thank you for your trust.

Cut along the dotted line and send it to our address:



REGISTRATION CARD

The possibility of also registering on our website, www.opopop.cz

First name.....	Product serial number.....
Surname.....	Seller.....
Street address.....	Product type.....
City.....	
Postcode.....	
Telephone number (optional).....	Signature.....
Email	





OPOP, spol. s r. o.

Zašovská 750

757 01 Valašské Meziříčí

Bank details:

Komerční banka a.s., account number: 1608851/0100

Business ID No: 47674105, VAT ID No: CZ 47674105

Telephone: Sales Department: 571 675 589; Secretariat: 571 611 250; Production: 571 675 405

Supply: 571 675 114; Finance: 571 675 472

Fax 571 611 225
